



**BOBBER**



**Owners Manual**

# C o n t e n t s

Preface	1	Spark Plug Selection and Replacement	25
Important Notice	2	Changing and assembly of Air Filter	26
<b>Motorcycle Safety</b>		Throttle Inspection and Adjustment	27
Safe Riding Rules	4	Clutch Adjustment	28
Protective Apparel	5	Drive Chain Check, Adjustment and Lubrication	29
Modification	5	Front wheel hydraulic left, right disc brake	30
Loading	5	Rear Wheel Hydraulic left, right disc brake	32
<b>Instruction</b>		Front Wheel Disassembly and Replacement	34
Parts location	7	Rear Wheel Disassembly and Replacement	35
Parts function	10	Accumulator Maintenance	36
<b>Operation</b>		Cooling system	37
Pre-ride Inspection	19	Fuse replacement	39
Starting the engine	19	Cleaning	40
Riding	21	Storage guide	40
Running-in	21	Maintenance Schedule	41
<b>Maintenance</b>		DD125E-9、DD350E-2 SPECIFICATION	44
Checking and changing of Engine oil	23	Motorcycle circuit diagram	45

# P r e f a c e

The manual introduces to you basic operation and method of maintenance of this motorcycle. Please read the manual carefully before driving the motorcycle. Proper operation and maintenance of the motorcycle will ensure less trouble and optimum performance and service life. The authorized service dealers at various areas will take their pleasure in providing you with more technical consultations and after-sales services.

The data, instructions, specifications, and pictures demonstrated in the manual are based on the latest design information available at the time of approval for printing. Our company reserves the right to make changes at any time without notice of changed parameters and other information.

Thank you for purchasing motorcycle. Wish you a comfortable and pleasant long trip in the future.

## IMPORTANT NOTICE

The engine of this motorcycle rotates at high speed. In order to make sure that the engine can run normally, prolong its service life and safeguard your interests, please operate the motorcycle according to the following regulations:

1. During the first 1,000 km, avoid full throttle and never labour the engine. The rotating speed of the engine should be strictly restricted to less than 6000rpm.
2. After the first 500km, and every 3000km in the future, please clean the engine and change engine oil in accordance with the requirements of Operation and Maintenance Manual.

## Special Attention

If you operate the motorcycle without following traffic regulation and instructions in the manual, or under abnormal conditions such as driving on terrible bumps or overloaded, safety accidents or equipment damage may occur.

This manual should be considered a permanent part of the motorcycle and should remain with the motorcycle when resold.

The company reserves all the rights of the manual. No part of this publication may be reproduced without written permission of the company, and any violation will be brought to justice.

# MOTORCYCLE SAFETY

## WARNING

When riding your motorcycle, you must pay attention to traffic safety. Only after you have checked your motorcycle can you drive it.

## SAFE RIDING RULES

Before you start your engine, you must check the motorcycle to prevent accidents or equipment damage. Any motorcycle driver must pass the test and get the license.

Before the traffic administration validates one's permit for driving. NEVER lend your motorcycle to any rider without drive license.

Make yourself conspicuous to help avoid the accident that wasn't your fault:

Wear bright-colored clothing. Don't keep extremely close to other motorcycles. Properly use signal devices such as turn signal lights and horn. Lane sharing is prohibited. Strictly obey all local traffic regulations. Excessive speed is a factor in many accidents. Obey the speed limits, and NEVER travel faster than conditions warrant.

Keep both hands on the handlebars and both feet on the footpegs while riding. The passenger should hold on firmly the driver's waist with both hands and keep both feet on the passenger footpegs.

## PROTECTIVE APPAREL

A motorcycle rider usually has his/her head injured in an accident. In order to ensure personal safety, the rider should wear a helmet, goggles, boots, gloves etc. The passenger should wear the same right gear. The temperature of the muffler is very high when the motorcycle is ridden. The passenger should wear boots or shoes high enough to cover his/her ankles to prevent his /her feet from being scalded. The rider should wear close-fitting clothes to prevent loose clothing catching the handlebars, kick starter, footpegs and tyres.

## MODIFICATIONS

### WARNING

Modification of the motorcycle or change of original equipment may render the motorcycle unsafe or illegal. Obey all traffic regulations stipulated by the local traffic.

If you have any better suggestion, you can inform us through correspondence. It is advisable to modify your motorcycle only after being agreed by us. Otherwise, you will be responsible for all consequences.

## LOADING

### WARNING

The motorcycle is sensitive to changes in weight distribution. Improper loading of cargo can impair the motorcycle's performance and stability.

Keep cargo low and close to the centre of the motorcycle. Load weight equally on both sides of the motorcycle to minimize imbalance. As weight is located further from the centre of gravity, handling is proportionally affected.

Properly adjust the tire pressure and the spring of the rear shock absorber according to the load weight and road conditions.

Firmly mount loads on the motorcycle in order to ensure stable handling.

Avoid fastening large or heavy loads to handlebars, front forks or dashboard, otherwise it can adversely affect stability and handling. NEVER exceed the maximum weight limit of 150 kg.

## ACCESSORIES

Accessories produced by our company have undergone special design and test, and can render the motorcycle safe. They are optional for users. Users will take responsibility for their selection, installation and use of accessories not produced by our company. Please obey safe riding rules and follow the next points:

Carefully check your accessories, make them out of sight line, reduce distance between them and the ground and side dip angle, and keep suspension or steering device from moving or affect handling. Avoid attaching any electrical equipment. Otherwise it can bring trouble to the electrical system.



## INSTRUCTIONS

### PARTS LOCATION

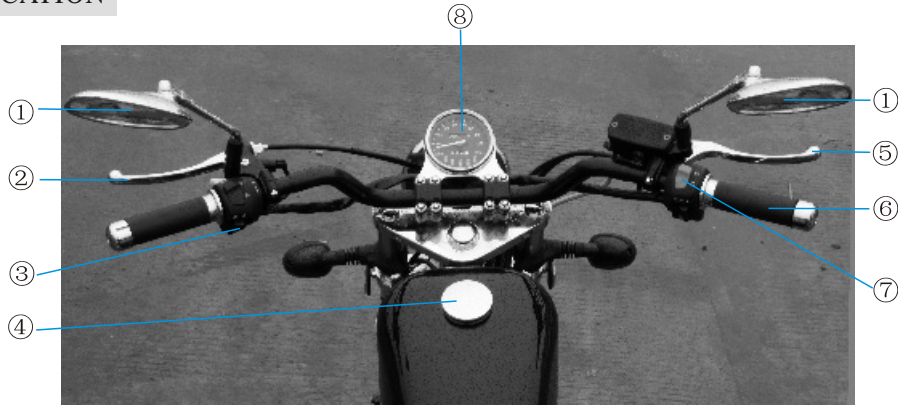

1. Rearview mirror
2. Clutch lever
3. Left handlebar control  
(horn button, Headlight  
dimmer switch, turn signal  
switch)
4. Fuel tank cover
5. Front brake lever

6. Throttle grip
7. Right handlebar control  
(starter button, headlight  
switch, engine cut-off)
8. Instrument panel

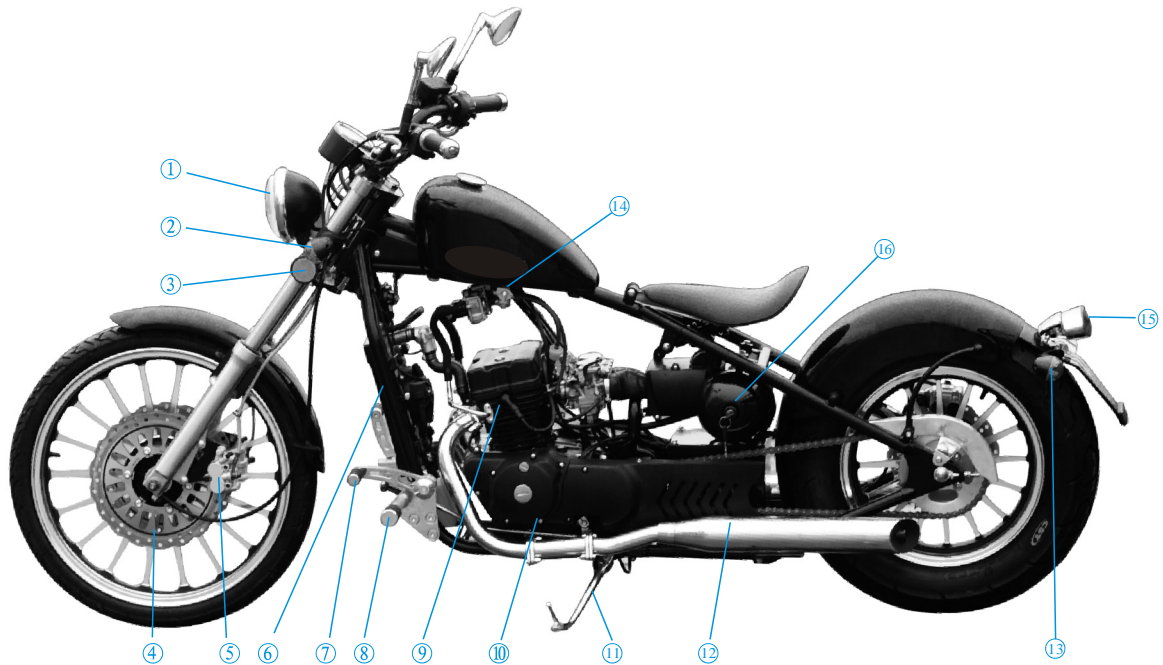

1.Front Headlight 2.Front left turn signal light 3.Side reflector 4.Front brake disc.L 5.Front brake pump.L  
6.Radiator cover 7.Gearshift lever 8.Left footpeg 9.Engine 10.Engine serial number 11.Side rack  
12.Left exhaust 13.Left rear indicator 14.Fuel switch 15.Tail light 16.Ignition switch

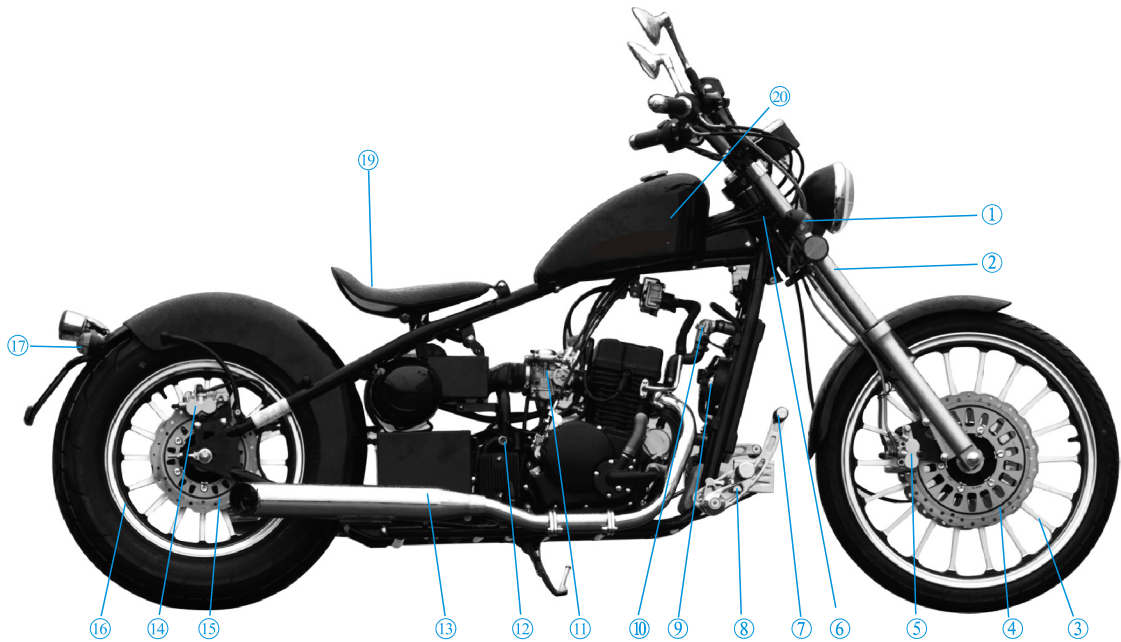

- 1.Front right turn signal light 2.Front shock absorber 3.Front wheel 4.Front brake disc.R 5.Front brake pump.R  
 6.Frame name plate 7.Rear brake pedal 8.Right footpeg 9.Radiator 10.Sensor 11.Carburetor 12.Charger  
 13.Right exhaust 14.Rear brake pump 15.Rear brake disc 16.Rear wheel 17.Rear right turn signal light  
 19.Seat 20.Fuel tank

## PARTS FUNCTION

### [INSTRUMENTS AND INDICATORS]

- ① Left turn signal indicator
- ② Odometer
- ③ High beam indicator
- ④ Neutral gear indicator
- ⑤ Speedometer
- ⑥ Right turn signal indicator
- ⑦ Water temperature alarm indicator
- ⑧ Ignition switch

[Water temperature alarm indicator]

The Water temperature alarm indicator is on when engine temperature is too high; and the alarm indicator is off when the temperature turns down. When open the ignition switch, Water temperature alarm indicator in the odometer will on; after started the engine, the trouble light put out. If the trouble light is blinking after started the motorcycle, it described the problems in EFI system. Tester can be used for checking the fault code and relevant parameters and then solve them.

[Ignition switch]

The ignition switch is located in the electric box.

“(X)” Described the entire circuit is cut off; the engine cannot be operated; the key can be taken out.

“(O)” Described the entire circuit is closed; the engine can be operated; the neutral gear indicator is on; the key can not be taken out.



## STEERING LOCK

The lock ① is below the steering stem. To lock the steering, turn the handlebars all the way to the left, turn the ignition key clockwise to lock while pushing in, and then remove the key.

**Caution: Always lock the steering when the motorcycle is not run.**

## LEFT HANDLEBAR CONTROLS

1. horn button
2. turn signal switch
3. passing switch
4. headlight dimmer switch

[Horn Button]

Press the horn button ① to sound the horn if necessary.

[Headlight Dimmer Switch]

Select “ $\text{D}$ ” for low beam and “ $\text{D}$ ” (blue) for high beam.

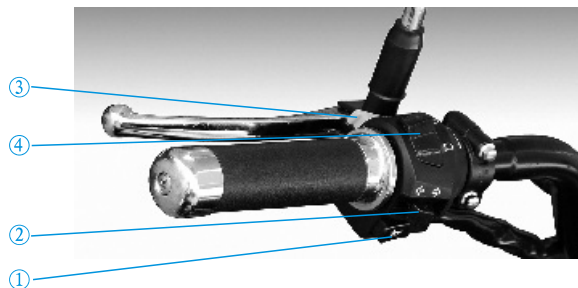
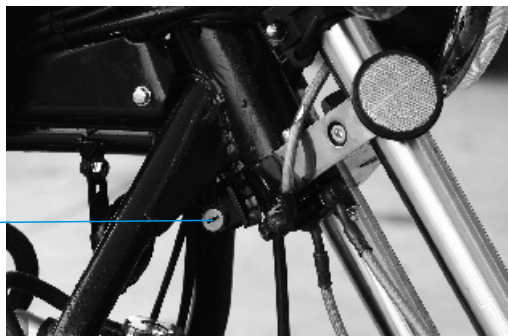

### [Turn Signal Light Switch]

The turn signal light switch has three positions. If need to turn left, move the turn signal light switch to "⇒", both front and rear left turn signal lights on, and if need to turn right, move the turn signal light switch to "⇐", both front and rear right turn signal lights on; press turn signal off with both signal lights off. The switch will automatically return to mid. Position.

### [Passing Switch]

The passing switch is on the left handlebar. Select for low beam and press the "passing" switch, and the both low beam and high beam lights are on. Release the switch and only low beam light is on. When the motorcycle overtakes at night, use the "passing" switch instead of constantly turning on and off the headlight dimmer switch. Therefore, the operation becomes so simple to ensure safe riding.

### [Choke valve handle]

The choke valve handle is on the carburetor.

To start a cold engine, turn the choke valve handle downwards to close the choke valve.

To start a warm engine or ride normally after starting, turn the handle upwards to open the choke valve.

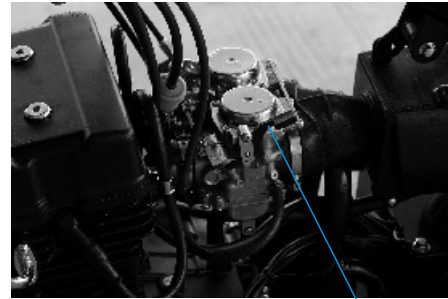
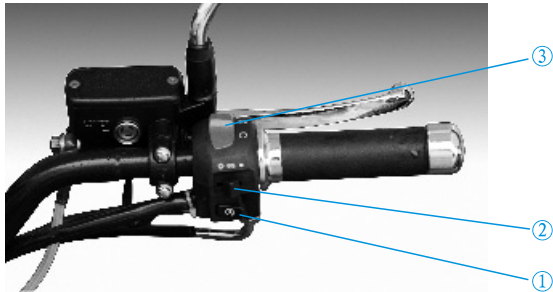

Choke valve handle

### RIGHT HANDLEBAR CONTROLS

① Electric starter button ② Headlight switch ③ Engine cut-off switch

### [Electric Starter Button]

The starter button is one of the right handlebar controls

1. Make sure that the gear is shifted to neutral and the fuel switch is in the position of "☐", or grasp the clutch lever to separate the clutch when the motorcycle remains in any other gear.
2. Open the cover of the ignition switch lock, insert the key into switch and turn it 90 degree anticlockwise, remove the key and close the lock cover, move the ignition switch 30 degree anticlockwise to the internal gear position.
3. Turn the engine cut-off switch to "○" and press the electric starter button "⚡", at the same time, slightly opening the throttle can crank the engine.

### [Headlight Switch]

The head light switch has three positions "☛", "≧○○≦" and "●".

"☛": headlight, taillight, metre lights and license plate light on.

"≧○○≦": front position light, taillight, license plate light on.

"●": headlight, taillight, front position light, license plate light off.

### [Engine Cut-off Switch]

Engine Cut-off is one of the right handlebar controls.

"⊖": meaning that the whole circuit is cut off, the engine can't be cranked or to stop the running engine.

"○": meaning that the whole circuit is switching-in, the engine can be cranked. To start the engine, the engine cut-off switch must be turned to "○".

## FUEL TANK AND CAP

Fuel tank capacity is 8L with 2.7L reserve fuel.

We recommend you to use unleaded petrol 90#. If there is no this kind of petrol, you can use petrol over 90# with low lead.

### CAUTION

Don't overfill the tank (there should be no fuel in the filler neck).

After refuelling, make sure that fuel cap is closed securely.

While refuelling, fuel should be filtered through the filter at the mouth of the tank of specially filtered before.



[How to Open the Fuel Cap]

Move the fuel tank cap anticlockwise, it can be opened; and then move it clockwise, it can be closed.



Veritable fuel cap

## FUEL SWITCH

The fuel switch is below the left side of the fuel tank. Turn the fuel switch handle to "●" (off), fuel supply is stopped. The handle remains at the position when the motorcycle is not operated. When riding, you should turn the handle to "☐" (on), fuel is supplied normally (fuel flows into the Carburetor). When the handle is turned to "☐" (with a horizontal line), the reserve fuel is supplied (only when the normal fuel runs out). When the handle is turned to "☐" (with a horizontal line and a vertical line), please refuel the tank because only 2.7L reserve fuel is not enough.

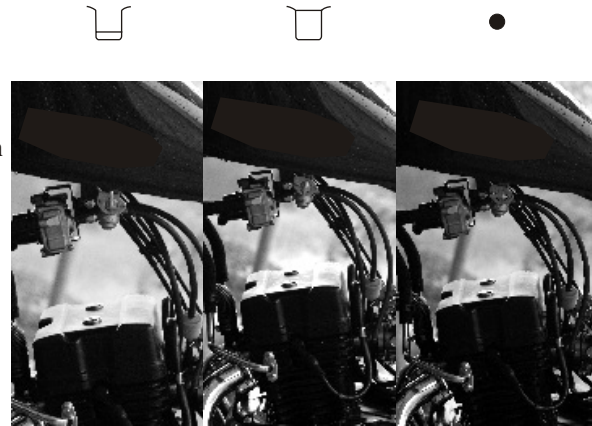

## CAUTION

The fuel switch handle should remain in the position of "☐" (with a horizontal line) when refuelling. Otherwise, there is no reserve supply when fuel runs out.

Proper use of the fuel switch can prevent the motorcycle from breaking down because of shortage of fuel.

## ENGINE OIL

Engine oil quality is the chief factor affecting engine performance and service life. So the engine oil should be selected according to requirements, not superseded by general engine oil, gear oil and vegetable oil.

The motorcycle uses engine oil SAE10w/40 API SG when being sold. If you want to change the oil for other engine oil, use only quality engine oil certified to meet or exceed requirements for service SG. The viscosity grade of engine oil should be based on the atmospheric temperature in your riding area as the picture attached show. To change engine oil, you should drain existing oil out of crankcase, clean the case with detergent kerosene and then refuel new oil according to the provision.

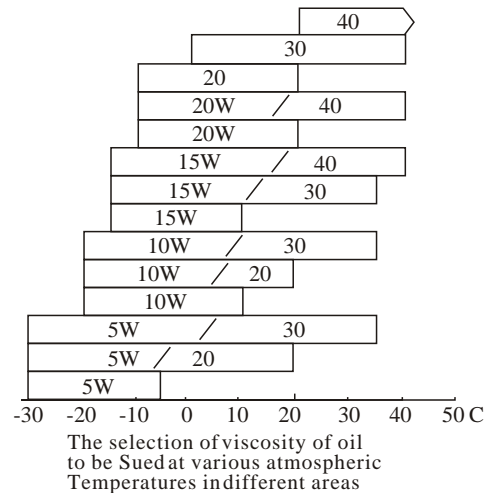

## TUBELESS TYRES

Proper air pressure will provide the maximum stability, riding comfort and tyre life.

Load	Tyres pressure(kpa)	Tyres pressure(kpa)
Driver only	Front:225	Rear:225
Driver and a passenger	Front:250	Rear:250

## WARNING

Operation with excessively worn tyres is hazardous and will adversely affect traction, stability and handling. Improper tyre inflation will cause abnormal tread wear and create a safety hazard. Under inflation may result in the tyre slipping on or coming off the rim and causing an accident.

### NOTE:

Tyre pressure should be checked before you ride while the tyres are cold. Check tyres for cuts, imbedded nails or other sharp objects. Check tyres for dents or deformation. If there is any damage, see your authorized service dealer for repair or replacement. Replace tyres before tread depth at the centre of the tire reaches the following limit:

Minimum tread depth(mm)	
Front:1.5	Rear:2.0

# OPERATION

## PRE-RIDE INSPECTION

Inspect your motorcycle before you ride it. The items here will only take a few minutes to check and can save trouble shooting time while you are driving and ensure your safe riding.

Oil level---check the level and if necessary, add oil. And check for oil leaks

Front and rear brakes----check operation and if necessary, adjust free play.

Tyres----check condition and pressure of both front and rear tyres. If necessary, charge or repair.

Throttle---check for smooth opening and full closing in all steering positions,

Connection of steering line, and free play of handle. If necessary, adjust or change.

Lights and signals-----check that the headlight, taillight, turn signals and horn function properly.

If necessary, adjust or repair.

Chain-----check that the chain functions and is lubricated properly. If it is severely worn or damaged, change it.

Steering -----check the flexibility and stability of steering. If necessary, you should adjust it.

## STARTING OF ENGINE

### WARNING

NEVER run the engine in a narrow area lest the exhaust should not easily diffuse.

NEVER start the engine when the engine is in gear, otherwise it will cause equipment damage and an accident.

[Preparing to ride]

Insert the ignition key and turn it to “⊙” , and turn the ignition switch to “□” . Turn the fuel switch handle to “⊙” , and turn engine cut-off switch to “⊗” , pull down the choke valve handle to close the valve (not necessary if the engine is warmed up). Shift the gear to the neutral position with neutral gear indicator on (green), or shift to any gear, grasp the clutch lever and start the engine (electric starting).

Press the electric starter button “⊗” and open the throttle slightly to start the engine.

NOTE:

1. Don't press the electric button "⊗" for more than 3-5 seconds at a time, otherwise the battery may be discharged quickly.
2. Release the starter button immediately after the engine is cranked
3. Don't press the starter button while the engine is running, otherwise it may adversely affect the engine.
4. Release the starter button for minutes when the engine is not able to start for three consecutive, otherwise the battery may be discharged quickly and used for a shorter period of time.

## RIDING

### [Shifting Gears]

Warm up the engine.

1. While the engine is idle, release the clutch, put your foot on the gearshift pedal to shift into a low gear (first gear)
2. Gradually accelerate the engine and slowly loose the clutch handle. Coordinate them to start riding steadily.
3. When the motorcycle rides steadily, feedback oil enables the engine to slow down, release the clutch again and pull the gearshift pedal up to shift into second gear. It is the same for changing to any other gear.

## RUNNING-IN

During the initial running-in of 1000km, avoid full throttle use and never labour the engine by shifting gears. Strictly restrict the engine to less than 6000 rpm. During the initial running-in of 500km, the maximum speed should not be more than 55km/h and during the first 500-1000km, no more than 70km/h. Timely performance of the running-in maintenance will ensure optimum service life and performance from the engine. Running-in speed in every gear is shown in the right table.

### Running-in speed

Gear	Speed
First	0~15km/h
Second	10-30km/h
Third	20-45km/h
Fourth	30-55km/h
Fifth	50-70km/h

## Warning

Never shift gears when the clutch is not released and the throttle is not decreased. Otherwise it will bring damage to the engine, the driving chain and other components.

### [Braking]

While slowing the motorcycle down, decrease the throttle first and then apply both front and rear brakes together to slow down or stop.

To apply an emergency brake, close the throttle first, release the clutch and promptly use both front and rear brakes at the same time.

Independent use of only the front or rear brake reduces braking performance, rapidly applying brakes may cause the front or rear wheel to lock immediately, resulting in loss of control of the motorcycle and bringing about an accident.

When approaching a corner or turn, close the throttle fully, and slow the motorcycle down by applying both front and rear brakes at the same time, Otherwise it may cause loss of control and a skid or overturn.

When riding on wet or loose surfaces, manoeuvre steadily. Immediately speeding up, rapidly applying brakes and turning may result in a loss of motorcycle control.

### [Stopping]

Gradually close the throttle, decelerate the motorcycle, and then gently apply both front and rear brakes together to stop steadily, turn off the ignition switch and lock the head. In case of emergency, press the engine cut-off switch to cut off the engine, At last use the centre stand to support the motorcycle and turn the fuel switch to "●".



# Maintenance

Checking and changing of engine oil, and cleaning of FILTER.

## [Engine Oil Level Check]

Check the engine oil level each day before riding the motorcycle. There is a dipstick ① behind the left crankcase cap for checking the oil level. The level must be maintained between the upper ② and lower ③ level marks on the dipstick.

Put the motorcycle on the centre stand on level ground, remove the dipstick, wipe it clean, and reinsert the dipstick without screwing it in. Remove the dipstick to check the oil level. If required, add the oil certified to meet requirements for service SAE10W/40 API SG.

up to the upper level mark. Do not overfill. Reinstall the dipstick. Check for oil leaks.

### CAUTION:

Running the engine with insufficient oil can cause serious engine damage.

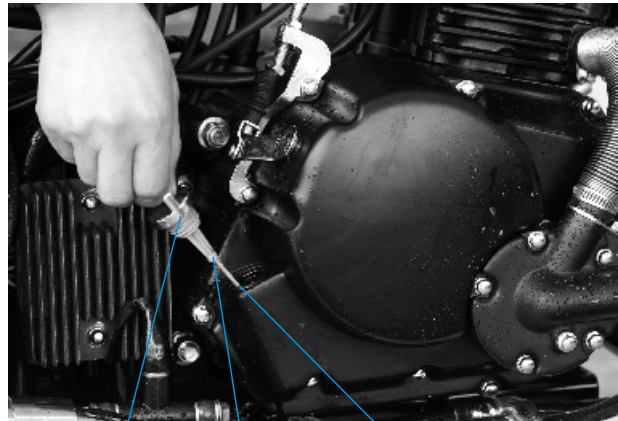

① Dipstick ② Upper level mark ③ Lower level mark

### [Engine oil change and oil filter clean]

Warm up the engine and drain the engine oil after cutting off the engine. Place an empty container under the engine. Unscrew the drain screw ① to drain the oil completely and then tighten the drain screw. Add about 1.6L kerosene. After that, cut off the engine, press the starter button for several times to clean the components in the crankcase the drain screw. Tilt the engine for 2 to 3 hours.

Add 1.9L new oil after the oil in the case is drained completely. If you go to a specified service dealer, you can require servicemen to open the right crankcase and remove the oil filter screen ② for cleaning.

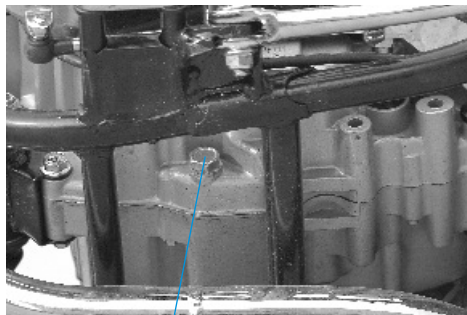

① Drain screw

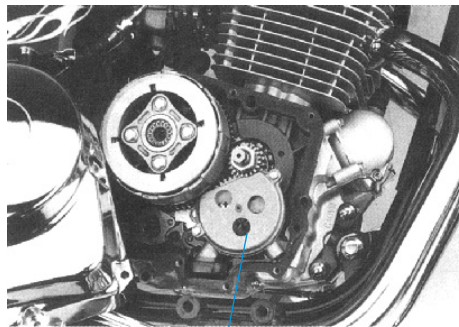

② Oil filter screen

#### NOTE:

When riding on dust road, you should change the engine oil and clean the oil filter more frequently.

## SPARK PLUG SELECTION AND REPLACEMENT

### [Spark Plug Selection]

1. When riding usually at low speed or under low temperature in winter, you are recommended to select A5RTC or CR5HSA spark plug of which centre electrode is black plug of which centre electrode is black.
2. When riding usually at high speed or under high temperature in summer, you are recommended to select A7RTC CR7HSA spark plug of which centre electrode is gray.
3. You are recommended to select AR6HSA (furnished in the factory) under normal conditions.

### [Spark Plug Inspection and Replacement]

Disconnect the spark plug cap from the spark plug.

Clean any dirt from around the spark plug bases.

Disassemble the spark plug using the spark plug wrench in the tool kit and clean deposits or carbon fouling with a wire brush. Inspect the electrode and central porcelain for damage or erosion. If the erosion or damage is heavy, replace the plug. Check the gap of spark plug side electrode ① using a feeler gauge and adjust the gap to 0.6-0.7mm.

Make sure the plug washer is in good condition.

Thread the spark plug in by hand to prevent cross-threading and then tighten it with a spark plug wrench.



① Side electrode

## AIR CLEANER REPLACEMENT

The air filter should be serviced at regular intervals. Service more frequently when riding in unusually wet or dust areas.

Remove the seat the protect plate, screw out the screw ②, disassemble the air filter cover ①, and take off the air filter parts ③, and then assemble the new filter parts. Please use the new filter or the high quality air filter of the same model according to the User' s Manual, otherwise the engine will make frayed or decrease its work capability.

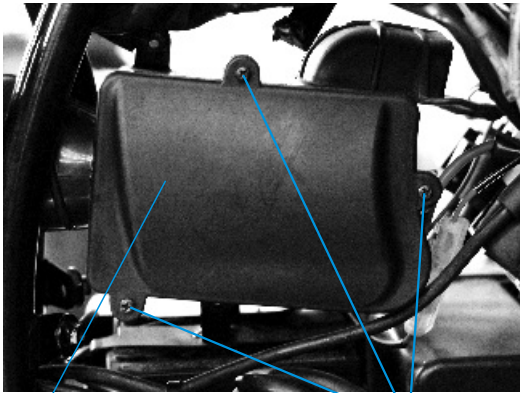

① Air filter cover

② Screw

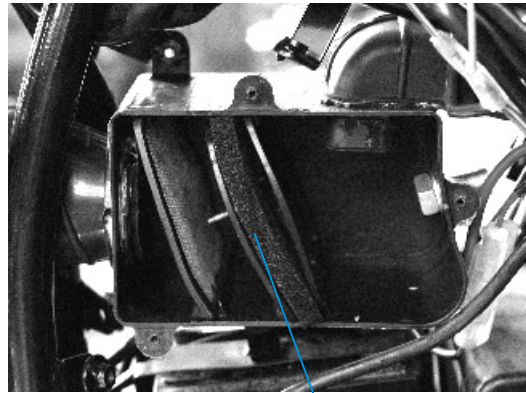

③ Air filter parts

## THROTTLE INSPECTION AND ADJUSTMENT

### [Throttle Cable Inspection]

Check for smooth throttle grip full opening and full closing in all steering positions. Check that the throttle cable between the throttle grip and the carburetor is proper. If the cable is twisted or improper, replace the cable or put it in proper position.

Free play at the tip of the throttle grip is 2 to 6mm. If necessary, unscrew the lock nut ① and turn the upper adjusting nut ②. If not enough, remove the carburetor cover and adjust the adjusting nuts a and b until it is proper.

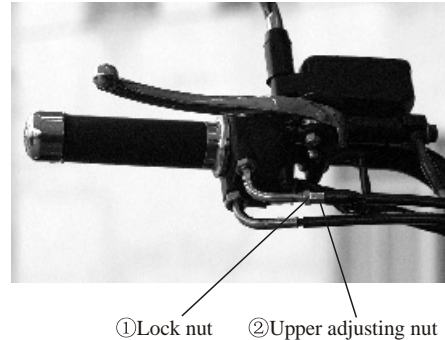
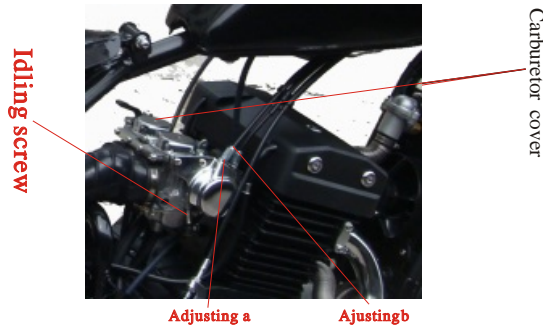

## CARBURETOR IDLE SPEED ADJUSTMENT

Start the engine and warm it up. Operate after the engine is warmer.

Adjust the carburetor-idle to  $1500 \pm 150$  rpm by turning the idling bolt ①.

Increase by turning clockwise and decreasing anticlockwise.

## CLUTCH ADJUSTMENT

Free play at the tip of the left clutch lever is 10 to 20mm. If adjustment is necessary, unscrew the lock nut ① positioning the clutch cable on the locator ② of the crankcase and adjust it. Turn the lever as (A) shows to decrease free play. Turn as (B) shows to increase. The same for the adaptor ③ on the left clutch lever.

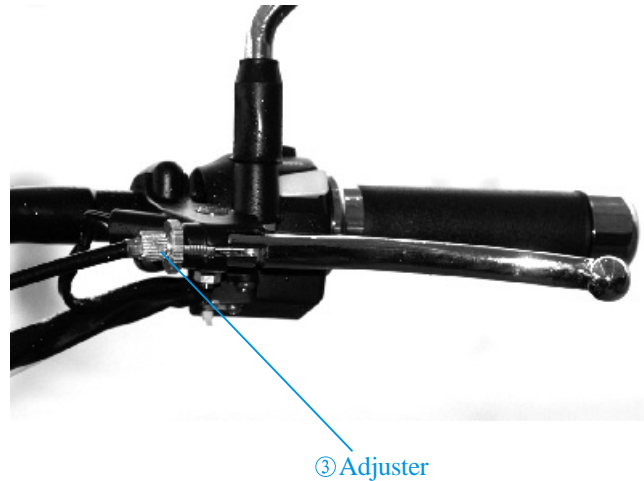
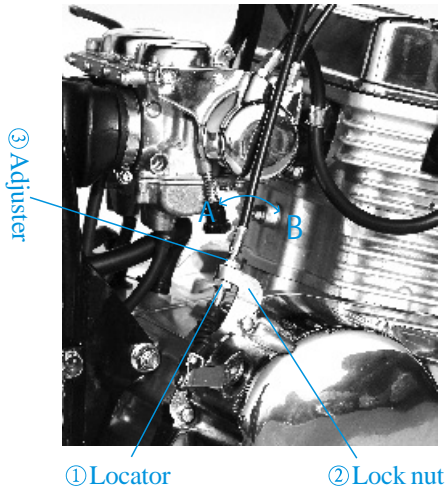

## DRIVING CHAIN CHECK, ADJUSTMENT AND LUBRICATION

### [Driving Chain Check]

Check for wear of the driving chain ①. Lubricate it when it is short of oil. Use the centre stand to support the motorcycle, and step on the gearshift pedal to shift into neutral. Place your finger between both front and rear wheels, and swing the chain ① up and down to adjust the chain to 10-20mm.

### [Driving Chain Lubrication]

Remove a chainlock clip ② with pliers carefully and disassemble the chain. Clean the chain in the detergent solvent and then dry it. Check for wear and damage of every part of the chain. If necessary, replace it. Lubricate the chain with an appropriate amount of motor oil or chain lubricant oil. Install the driving chain in the reverse order of disassembly and adjust it.

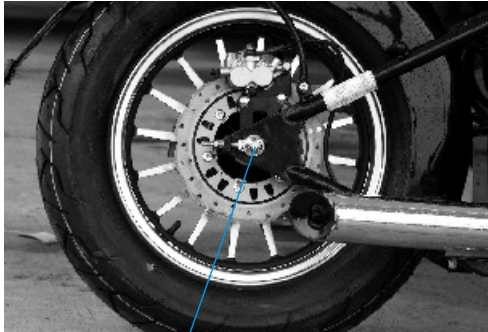

⑥

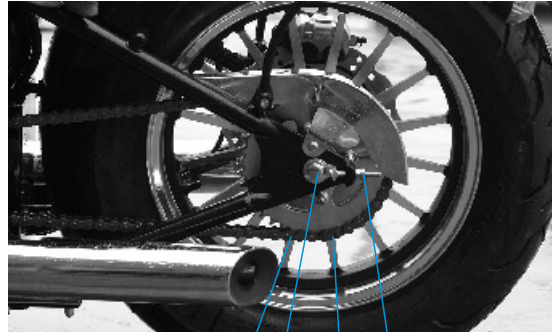

①

⑦

②

⑧

**NOTE: WHEN INSTALLING THE CHAINLOCK CLIP, KEEP THE MOUTH OF THE CLIP OPPOSITE TO THE NORMAL MOVING DIRECTION.**

## FRONT FLUID LEFT AND RIGHT DISC BRAKE

### [Brake Fluid]

Pay attention to the fluid level in the brake fluid reservoir of the right brake lever. If the level descends, add the brake shoe wears, the fluid level will descend as the fluid automatically flows into the fluid is an important part of fluid disc brake regular maintenance.

Brake fluid reservoir

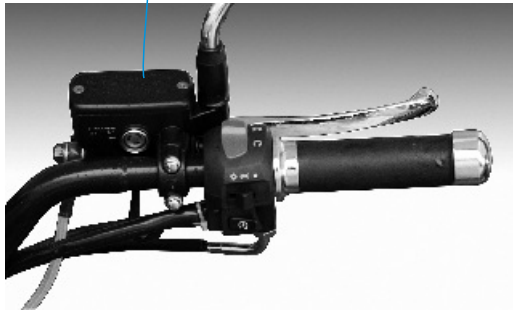

(Right) Brake calipers

Brake disc

### WARNING

The brake fluid has strong corrosion. If it is drunk wrongly, force to spit it out. If eyes or skin are contacted with it, clean with plenty of water and see a doctor.

1. Never use the fluid that has been used or that in an open container. Never use the fluid left last time or that having been stored for a long period of time as the fluid has absorbed water from the air.
2. The brake fluid is strongly corrosive. Never have the fluid splattered on painted or plastic surface.



### [Brake Disc]

The brake disc will be worn after being used for a period of time. In order to ensure that the brake system can function properly and reliably, replace the disc when it is extremely worn. The limit of motorcycle brake disc is 3.5mm, the same marked on the brake disc.

### WARNING

Don not ride your motorcycle after you have just replaced the disc with a new one. Grasp and release the front brake lever several times until the brake disc fits the brake calipers well, thus returning the front brake lever to normal free play.

### [Brake System]

Pre-ride inspection must be performed every day on the following item:

- a) Check the fluid level in the fluid reservoir;
- b) Check the brake system for fluid leakage;
- c) Check the fluid tube and the reservoir for leaks or cracks;
- d) Check wear of the brake disc;
- e) Ensure the right and A. unchanged free play for the front brake lever at anytime.

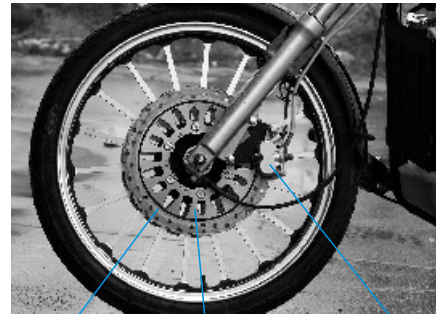

Brake disc    Wear mark    (Left) Brake calipers

### WARNING

1. The fluid disc brake operates under high pressure the fluid at the frequency interval no longer than that has been established in the manual.
2. If it is necessary to maintain the brake system or the disc, go to your authorized service dealer for the sake of safety.

## REAR FLUID DISC BRAKE

### [Brake Fluid]

Pay attention to the fluid level in the rear brake fluid reservoir. If the level descends, add the brake fluid specified by our company. If the brake shoe wears, the fluid level of the rear brake fluid reservoir will descend as the fluid automatically flows into the fluid is an important part of fluid tube. Checking and adding brake fluid is an important part of fluid disc brake regular maintenance.

### WARNING

The brake fluid has strong corrosion. If it is drunk wrongly, force to spit it out. If eyes or skin are contacted with it, clean with plenty of water and see a doctor.

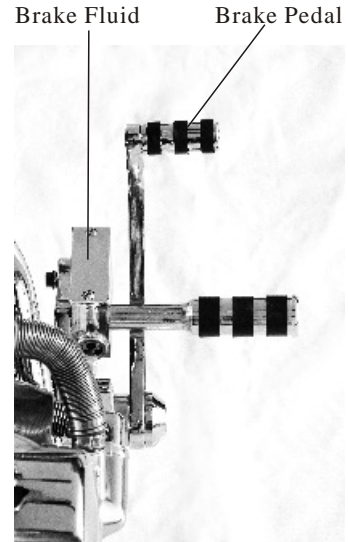

1. Never use the fluid that has been used or that in an open container. Never use the fluid left last time or that having been stored for a long period of time as the fluid has absorbed water from the air.
2. The brake fluid is strongly corrosive. Never have the fluid splattered on painted or plastic surface.

### [Brake Disc]

The brake disc will be worn after being used for a period of time. In order to ensure that the brake system can function properly and reliably, replace the disc when it is extremely worn. The limit of motorcycle brake disc is 3.5mm, the same marked on the brake disc.

## WARNING

Don not ride your motorcycle after you have just replaced the disc with a new one. Grasp and release the front brake lever several times until the brake disc fits the brake calipers well, thus returning the front brake lever to normal free play.

### [Brake System]

Pre-ride inspection must be performed every day on the following item:

- A.** Check the brake system for fluid leakage;
- B.** Check the fluid tube and the reserve air for leaks or cracks;
- C.** Check wear of the brake disc;
- D.** Ensure the rear brake step pole unchanged free play for the front brake lever at any time.



wear mark    brake disc    brake calipers

## WARNING

1. The fluid disc brake operates under high pressure the fluid at the frequency interval no longer than that has been established in the manual.
2. If it is necessary to maintain the brake system or the disc, go to your authorized service dealer for the sake of safety.

## FRONT WHEEL DISASSEMBLY AND REPLACEMENT

Unscrew the lock bolt ②, disassemble speedometer cable, remove the axle nut ①, unscrew the front wheel axle ③ and take off the front wheel (including brake disc). To replace the front wheel or brake disc, unscrew the brake disc lock bolt ⑤, and take off brake disc ④, the order of assembly is on the contrary.

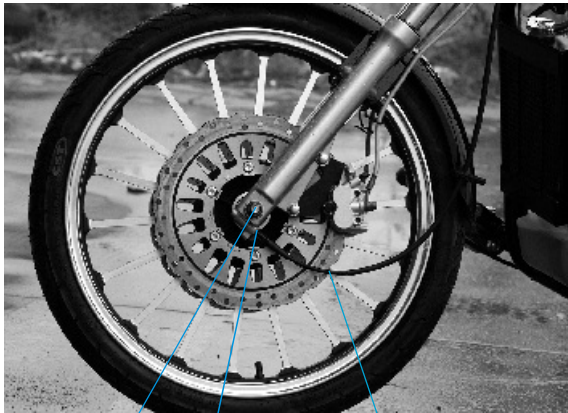

① ② ⑥

③ ④ ⑤

①Axle nut②Lock bolt ③ Front wheel axle④Brake disc ⑤Brake disc lockbolt ⑥Speedometer cable

## REAR WHEEL DISASSEMBLY AND REPLACEMENT

Use a jack to raise the motorcycle's rear wheel off the ground. Unscrew the rear brake adjusting nut①. hitch the other side of rear wheel axle with wrench, and remove the rear axle nut②.and take out the rear wheel axle③.Move the rear wheel forward and remove the driving chain from the drive gear, thus taking out the rear wheel.

- ①Rear brake disc adjusting nut
- ②Rear axle nut
- ③Rear wheel axle

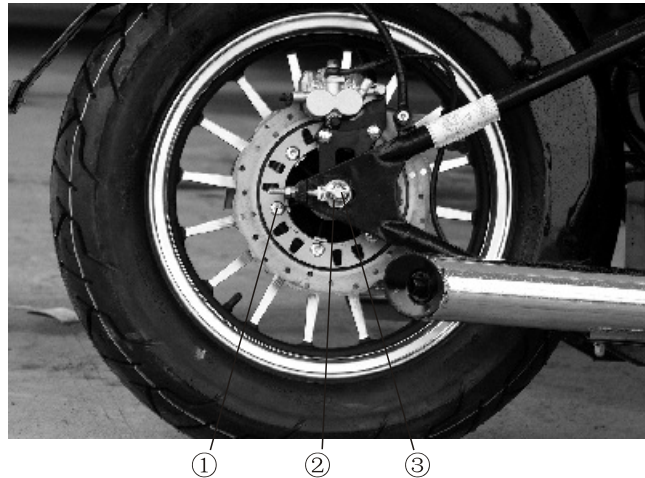

Front/rear wheel axle nut torch:40-50N.m, Apply the brakes for several times after adjusting the rear brake and the chain and installing the front and rear wheels, and then release both front and rear brakes to check that the wheels rotate properly.

## ACCUMULATOR MAINTENANCE

The motorcycle is supplied with 12V9A.h DC by a lead-acid accumulator. When riding the motorcycle, insufficient electrolyte in the accumulator will cause sulfuration and damage to its polar plate.

If electrolyte in accumulator runs out quickly, insufficient electrolyte will lower strength of the current thus making it hard to start the engine or bringing other trouble to the electrical system.

See the authorized dealer for repair.

Regularly check electrolyte in the accumulator that is under the right side frame cover. The electrolyte level should be between the upper and lower levels marked on the front side face of the accumulator,

If the electrolyte is below the lower level, take the accumulator out of the motorcycle, remove its cap and add distilled water carefully up to the upper level.

### Caution

1. when checking electrolyte or adding distilled water, make sure that the air tube is well connected with the air outlet of the accumulator.
2. Use only distilled water. Tap water will shorten the service life of the accumulator.
3. Remove the accumulator from the motorcycle to prevent its discharge and leakage when you are not to use your motorcycle for a long period of time. When removing, take the negative wire apart first. After charging, store the accumulator in well-ventilated area free of direct sunlight. If you want to store the accumulator in the motorcycle, you should remove the negative wire.
4. Regularly clean both positive and negative posts after removing the accumulator.  
To reinstall the accumulator, put the positive wire on the negative posts are firm.
5. Replace with an equivalent specified accumulator.

## COOLING SYSTEM

[The coolant]

The coolant consists of refrigerant and distilled water, has the function of anti-freezing. The coolant will prevent engine from overheating in neutral rotation or rotating in low speed. It also prevents radiator from harmful substance.

[In-pouring of coolant]

1. Place the motorcycle on flat ground, unfold the side stand.
2. Unscrew the coolant temperature switch, and pour the coolant into the radiator until it is filled.
3. Screw the cap on the radiator tightly.
4. Start the motorcycle. When the temperature of the coolant reaches about 80 degrees, stop the engine for 5 minutes, then open the radiator to pour the coolant into until it is filled, and screw the cap tightly. Pour the coolant circularly in this way three times.
5. Open the cap, pour 400ml coolant into the radiator, then the total capacity of coolant will be 1600ml. The coolant temperature switch and the cap, please refer to picture 1 and picture 2.

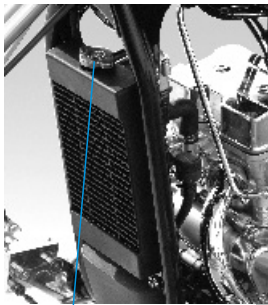

① Temperature control cap

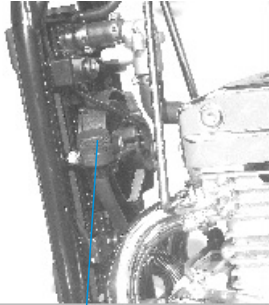

② Kettle cover

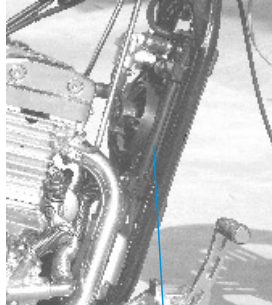

③ Water pipe

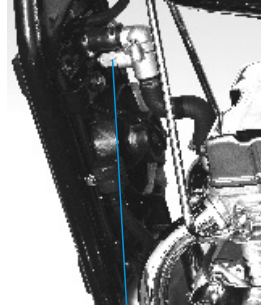

④ Sensor

### **[replacement of coolant]**

When the coolant is getting turbid ,or it finish a maintenance cycle, the coolant should be replaced.

Procedures:

- ① Place the engine on the flat ground and unfold the side stand.
- ② When the engine is under room temperature, put the vessel under the cap of radiator , and remove the cap of water tube to release the coolant.
- ③ Screw on the release-coolant bolt and the cap of radiator back.
- ④ Pour the coolant in according to the method of inpouring coolant ,the position of water ube is as indicated in picture 3

### **[function of sensor]**

When the temperature of engine reaches about 125℃, the sensor switch is on, so the coolant temperature alarm lamp in the instrument lights up, showing that the engine needs a rest from work, otherwise the life of the engine will be affected because of overheating. The position of sensor is as indicated in picture 4.

### **[caution]**

- ① Please use 3500 antifreezing antirust coolant.
- ② The coolant is poisonous, so it is unedible.
- ② It is forbidden to open the cap of radiator when the engine is in a state of high temperature, in case that the hot water with big pressure spurt out to harm anyone.
- ③ When repairing, please release all the coolant first if it is necessary to unscrew the cylindernut, in case that the coolant comes into the crankcase.

### **[servicing system maintenance]**

Check whether it is aleak per 1,000km.

- ① Check whether there's a leak in the joint of water pump and water tube.
- ② In order to check whether the circulator is damaged and aging, you can press the water tube by hand to see whether it has cracks, so that you can replace it in time.  
If there's a leak,please feedback to the maintenance man. Don't remove it privately.



## FUSE REPLACEMENT

Open the fuse box(white)by loosening the hexangular bolt on the battery box cover to replace the fuse box. There are 2 spare fuses for this motorcycles. Reinstall the main seat in reserve order of the removal and fix it after replacement. The specified fuses are 15A.

### Caution:

Replace with the specified fuse. Never use other conductive materials for replacement. Turn the ignition switch off before checking or replacing fuses to prevent accidental short-circuiting. To replace the fuse in the fuse box, remove the fuse box cover. Pull the old fuse out of clips. Push a new fuse into the clips and install the fuse box cover.

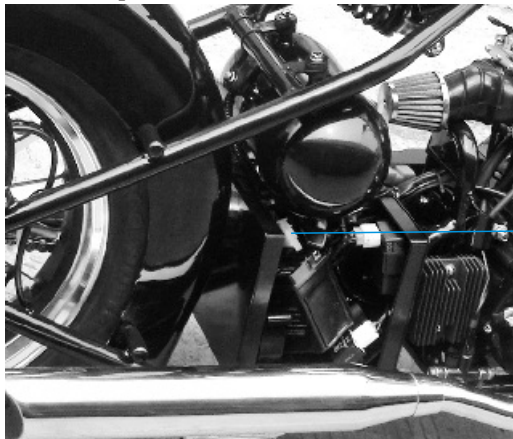

Fusion

## CLEANING

Clean your motorcycle regularly to protect the surface finishes and inspect it for damage, wear and oil seepage.

### CAUTION:

- ① High pressure water can damage certain parts of the motorcycle. Avoid spraying high Pressure water at the following areas: ignition switch, handlebar switches, instruments, muffler outlet and underseat.
- ② Prevent water from flowing into the muffler, spark plug and Accumulator.
  1. After cleaning, rinse the motorcycle thoroughly with plenty of clean water. Otherwise, these repairs may be forgotten by the time the motorcycle is removed from.
  2. Dry the motorcycle thoroughly. Start the engine and let it run for several minutes.
  3. Lubricate the driving chain.
  4. Test the brakes before riding the motorcycle in traffic. Several applications may be necessary to restore normal braking performance.

**WARNING:** Braking performance may be impaired immediately after washing the Motorcycle.

## STORAGE GUIDE

Extended storage, such as for winter (exceeding one month), requires that you take certain steps to reduce the effects of deterioration from non-use of the motorcycle. In addition, necessary repairs should be made **BEFORE** storing the motorcycle.

### Storage.

1. Clean and dry the motorcycle. Wax all painted surface.
2. Drain the fuel tank and carburetor. Spray the inside of the tank with aerosol rust-inhibiting oil.
3. Remove the spark plugs and pour a tablespoon (15-20ml) of clean engine oil into each cylinder. Press the starter button for several times after turning off the ignition switch to diffuse the engine oil evenly in the cylinders, and then reinstall the spark plugs.
4. Remove the accumulator. Store in a well-ventilated, dry, and cool area protected from direct sunlight.

**NOTE:** To remove the accumulator, dismantle the negative wire and then positive wire.  
When installing, fix the positive wire first and then negative and close the ignition switch.
5. Inflate the tyres to their recommended pressures. Place the motorcycle on blocks to raise both tyres off the ground.
6. Cover the motorcycle using cloth or other strongly air-permeable materials and store in a well-ventilated area, free of rain and direct sunlight with a minimum of daily temperature variation.

## REMOVAL FROM STORAGE

1. Uncover and clean the motorcycle.
2. Check the accumulator voltage. When the voltage is 12.3V below, slowly charge the accumulator as required. Install the accumulator,
3. Drain any rust-inhibiting oil from the fuel tank. Fill the fuel tank with fresh Petrol.
4. Perform all pre-ride inspection checks. Test ride the motorcycle in a safe area away from traffic. Check that the motorcycle functions properly.

## MAINTENANCE

Clean the motorcycle off dust and mud with dry cloth regularly. Dry the motorcycle when it is wet. Apply a little rust-inhibiting oil on zinc-coated and chrome-coated parts. Wax the painted parts to keep them bright and elegant. Lubricate every moving Part.

Inflate both front and each tyres properly. Measure the pressure with a gauge and make it in accordance with the specified requirements.

Check for bolts, nuts and screws to prevent a safety hazard resulting from loosening or falling-off of parts. Check for both front and rear brakes. Immediately adjust and replace if they are excessively worn or don't function properly.

## MAINTENANCE SCHEDULE

Perform the pre-ride inspection at each scheduled maintenance period.

Symbols in the table stand for as follows:

**I:INSPECT, CLEAN, ADJUST, LUBRICATE OR REPLACE IF NECESSARY.**

**C:CLEAN R:REPLACE A:ADJUST L:LUBRICATE I:INSPECT**

\* Should be serviced by your authorized service dealer unless the owner has proper tools and parts or is mechanically qualified.

\*\* In the interest of safety, we recommend these items be serviced only by your authorized service dealer.

## NOTES

- ①Service more frequently when riding in unusually dusty areas.
- ②At higher odometer readings, repeat at the frequency interval established here.
- ③Adjustment of the timing chain tension and the air valve clearance should be made only by your authorized service dealer for the sake of safety.

ITEM \ FREQUENCY		CYCLES	ODOMETER READING km(NOTE2)				NOTE
			1000km	4000km	8000km	12000km	
*	FUEL LINE		I	I	I	I	
*	THROTTLE OPERATION		I	I	I	I	
*	CARBURETOR			I	I	I	
	AIR CLEANER ELEMENT	NOTE1	C	C	C	C	
	SPARK PLUG	EVERY YEAR R	I	I	I	I	
	ENGINE OIL	EVERY YEAR R	First replace the engine oil when the bike runs for 500km, and then replace it every other 3000km				
*	ENGINE OIL STRAINER SCREEN						
**	TIMING CHAIN TENSION	NOTE3	A	A	A	A	
**	VALVE CLEARANCE	NOTE3	I	I	I	I	

ITEM \ FREQUENCY		CYCLES	ODOMETER READING km(NOTE 2)				
			1000km	4000km	8000km	12000km	NOTE
	DRIVE BELT		I.L	I.L	I.L	I.L	
	REAR BRAKE SYSTEM			I	I	I	
	BRAKE SHOE WEAR			I	I	I	
**	BRAKE FLUID TUBE	EVERY 4 YEAR R	I	I	I	I	
**	BRAKE FLUID RESERVOIR		I	I	I	I	
**	BRAKE FLUID	EVERY 2 YEAR R	Change every 2 years				
**	FRONT BRAKE SYSTEM		I	I	I	I	
*	REAR BRAKE LIGHT SWITCH		I	I	I	I	
	FRONT AND REAR LIGHTS	One month	I	I	I	I	
	CLUTCH		I	I	I	I	
*	SUSPENSION		I	I	I	I	
	RACK		I	I	I	I	
*	NUTS, BOLTS	One month	I	I	I	I	
**	TYRES/SPOKE	Three month	I	I	I	I	
**	STEERING HEAD BEARINGS	Six month	I			I	
**	CHAIN-TENSION ADJUSTER			I	IR		

## DD350E-2 SPECIFICATION

Part name	Item	Unit	Model or technical parameters	Part name	Item	Unit	Model or technical parameters
Complete Vehicle	Overall	mm	2400×830×1150	Engine	Model		DD262MN
	wgeelbase		1680		Type		2 Cylinders,4 Stroke,Water cooled
	Kerb weight	kg	170		Displacement	ml	320
	Rated load		150		Minimum fuel-consuming ratio	g/kw.h	354
	Maximum speed	km/h	≥140		Compression ratio		10.2:1
	Front type size and Pressure	L	80/90-21 225kpa		minimum idle speed	rpm	1500±100
	Rear type size and Pressure		160/80-16 225kpa		Spark plug gap	mm	0.6~0.7
	Fuel tank	L	8		Fuel type		RQ-93
	Reserve fuel		2.7		Lubrication type		SAE10W/40API SG
	Electrical	Ignition			CDI electric ignition	Rated power	kw
Headlight			12V35W/35W	Transmission		Normally joggled five gears	
Turn signal light Front/Rear			12V10W	Primary drive ratio		3.631	
Tail/brakelight			12V21/5W	First drive ratio		2.846	
License plate light			12V10W	Second drive ratio		1.777	
Spark plug			A6RTC	Third drive ratio		1.333	
Accumulator			12V9A.h	Fouth drive ratio		1.083	
Fuse			15A	Fifth drive ratio		0.913	
Horn			12V 105dB	Terminal		2.429	
					Fan initial temperature	℃	85
				Reflector initial temperature	℃	125	
				Coolant capacity	L	1.6	
				Coolant type		3500 antifreeze aritrust	

## DD125E-9 SPECIFICATION

Part name	Item	Unit	Model or technical parameters	Part name	Item	Unit	Model or technical parameters
Complete Vehicle	Overall	mm	2400×830×1150	Engine	Model		DD244MI
	wgeelbase		1680		Type		2 Cylinders,4 Stroke,Water cooled
	Kerb weight	kg	170		Displacement	ml	124
	Rated load		150		Minimum fuel-consuming ratio	g/kw.h	354
	Maximum speed	km/h	≥110		Compression ratio		10.2:1
	Front type size and Pressure	L	80/90-21 225kpa		minimum idle speed	rpm	1500±100
	Rear type size and Pressure		160/80-16 225kpa		Spark plug gap	mm	0.6~0.7
	Fuel tank	L	8		Fuel type		RQ-93
	Reserve fuel		2.7		Lubrication type		SAE10W/40API SG
	Electrical	Ignition			CDI electric ignition	Rated power	kw
Headlight			12V35W/35W	Transmission		Normally joggled five gears	
Turn signal light Front/Rear			12V10W	Primary drive ratio		3.833	
Tail/brakelight			12V21/5W	First drive ratio		2.769	
License plate light			12V10W	Second drive ratio		1.882	
Spark plug			A6RTC	Third drive ratio		1.450	
Accumulator			12V9A.h	Fouth drive ratio		1.217	
Fuse			15A	Fifth drive ratio		1.083	
Horn			12V 105dB	Terminal		2.923	
					Fan initial temperature	℃	85
				Reflector initial temperature	℃	125	
				Coolant capacity	L	1.6	
				Coolant type		3500 antifreeze aritrust	

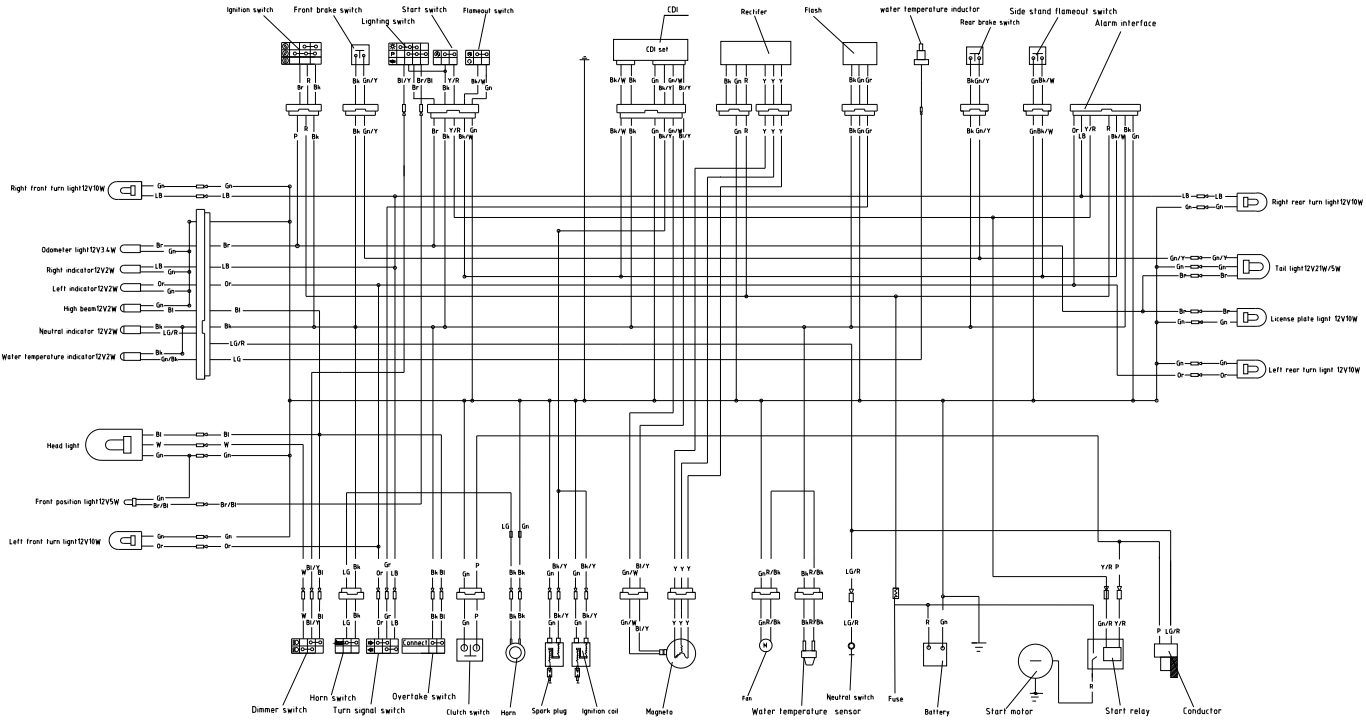

SYMBOL	Black	White	Blue	Brown	Green	Red	Yellow	Grey	Orange	Light Blue	Light Green	Pink
COLOR	Bk	W	Bl	Br	Gn	R	Y	Gr	Or	LB	LG	P

# Electrical System